

BASE STATION NEA SMART 24 V

Installation Instructions

CONTENTS

| | | | | | |
|----------|---|-----------|----------|-------------------------------------|-----------|
| 1 | Safety | 3 | 6 | Troubleshooting and cleaning | 15 |
| 1.1 | Used symbols and important safety instructions | 3 | 6.1 | Error messages and error handling | 15 |
| 1.2 | Intended use | 3 | 6.2 | Fuse change | 16 |
| 1.3 | General safety warnings | 3 | 6.3 | Cleaning | 16 |
| 1.4 | Requirements with regard to personnel | 3 | | | |
| 1.5 | Restrictions regarding use of product | 3 | 7 | Decommissioning | 17 |
| 1.6 | Compliance | 3 | 7.1 | Decommissioning | 17 |
| | | | 7.2 | Disposal | 17 |
| 2 | Versions | 4 | | | |
| 2.1 | Box contents | 4 | | | |
| 2.2 | Indicators and operating buttons | 4 | | | |
| 2.3 | Connections | 5 | | | |
| 2.4 | Technical data | 5 | | | |
| 3 | Installation | 6 | | | |
| 3.1 | Installation | 6 | | | |
| 3.2 | Electrical connection | 6 | | | |
| 3.2.1 | External change-over signal | 7 | | | |
| 3.2.2 | Pump/boiler/chiller | 7 | | | |
| 3.2.3 | Optional dew point sensor | 7 | | | |
| 3.2.4 | Pilot function for change-over heating/cooling | 7 | | | |
| 3.2.5 | External timer | 8 | | | |
| 3.2.6 | Room BUS | 8 | | | |
| 3.2.7 | System BUS | 8 | | | |
| 3.2.8 | Use of high temperature limiter | 8 | | | |
| 3.2.9 | Ethernet connection | 9 | | | |
| 4 | Commissioning | 10 | | | |
| 4.1 | First commissioning | 10 | | | |
| 4.2 | Connecting (pairing) / separating base stations | 10 | | | |
| 4.3 | Allocation of a room control unit to a heating zone (pairing) | 11 | | | |
| 4.4 | Perform connection test | 11 | | | |
| 4.5 | System configuration | 11 | | | |
| 4.5.1 | System configuration with microSD card | 11 | | | |
| 4.5.2 | Configuration with Nea Smart room control unit D | 11 | | | |
| 4.6 | Resetting the factory settings | 12 | | | |
| 5 | Exercise functions and safe mode | 14 | | | |
| 5.1 | Exercise functions | 14 | | | |
| 5.1.1 | Pump exercise | 14 | | | |
| 5.1.2 | Valve exercise function | 14 | | | |
| 5.1.3 | Frost protection | 14 | | | |
| 5.1.4 | Dew point monitoring | 14 | | | |
| 5.1.5 | High temperature limiter | 14 | | | |
| 5.2 | Safe mode | 14 | | | |



More information on the Nea Smart control system and all documentation available for download can be found at



www.rehau.com/neasmart

1 SAFETY

1.1 Used symbols and important safety instructions



Electrical voltage! Danger to life! Safety instructions are marked with this symbol.



Note

1.2 Intended use

The base station Nea Smart 24 V is intended

- for a single room regulation system (readjustment) with a maximum of 8 zones for heating and cooling systems,
- for the connection of a maximum of 12 actuators UNI 24 V and 8 Nea Smart R room control units D or Nea Smart R room control units, a pump, a CO signalling unit, a humidity sensor with potential-free contact as well as an external timer,
- for a fixed installation.

Every other use is outside its intended use for which the manufacturer cannot be held liable.

Modifications and conversions are expressly forbidden and lead to dangers the manufacturer cannot be held liable for.

1.3 General safety warnings



Electrical voltage! Danger to life! The base station is live.

- Prior to opening always disconnect from the mains and secure in such a way that it cannot accidentally be switched on.
- Disconnect all external voltages connected to the unit, e.g. at the pump and the boiler contacts and ensure these cannot accidentally be switched live.

Emergency

In case of emergency, disconnect the complete control system from mains.

Retain this manual and provide it to future owners.

1.4 Requirements with regard to personnel

Authorised specialists

The electrical installations must be performed according to the current VDE regulations as well as according to the regulations of your local electric power utility company. These instructions are intended for use by a qualified person who is holding an official **certificate** in one of the following professions: electrician or electronics engineer (according to the profession designations officially announced in the Federal Republic of Germany, as well as according to comparable professions within the European Community Law).

1.5 Restrictions regarding use of product

This unit is not intended to be used by people (including children) with restricted physical, sensory or mental skills except if they are supervised by a person responsible for their safety or have received instructions on how to use this unit.

Children should be supervised in order to ensure that they do not play with the device.

1.6 Compliance

This product is labelled with the CE Marking and thus is in compliance with the requirements from the guidelines:

- 2004/108/EG with amendments "Council Directive on the approximation of the laws of the Member States relating to Electromagnetic Compatibility"
- 2006/95/EG with amendments "Council for Coordination of the Regulations of EU Member Countries regarding the electrical equipment for use within certain voltage limits"

Increased protection requirements may exist for the overall installation, the compliance of which is the responsibility of the installer.

2 VERSIONS

2.1 Box contents

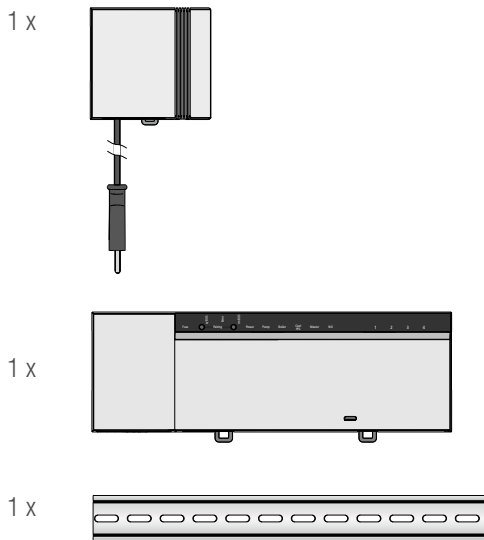

Fig. 2-1 Box contents

2.2 Indicators and operating buttons

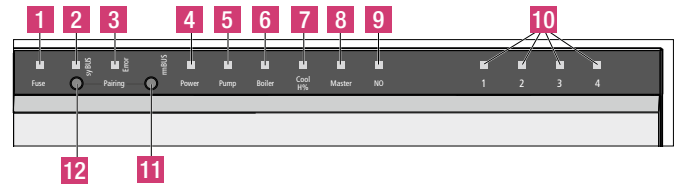

Fig. 2-2 Indicators and operating buttons

| No. | Designation | LED | Status | Function |
|-----|------------------------|--------|--------------------------|---|
| 1 | Fuse | red | permanent on | Fuse has blown |
| 2 | syBUS | yellow | permanent on Flashing | Shows syBUS activity Write access on microSD-card |
| 3 | Error | red | permanent on | High temperature limiter active |
| 4 | Power | green | permanent on | Base station ready |
| 5 | Pump | green | permanent on | Pump output active |
| 6 | Boiler | green | permanent on | Lights up when boiler output is active if the boiler relay is used for boiler control |
| 7 | Cool H% | blue | permanent on Flashing | Cooling mode active Condensation detected |
| 8 | Master | yellow | permanent on Flashing | Base station is defined as master Base station is defined as slave |
| 9 | NO | yellow | permanent on | Installation is configured for NO actuators (normally open) |
| 10 | Heating zones 1 - x | green | | Shows the respective status of the heating/cooling zones |
| 11 | rmBUS button | - | | Button for the rmBUS functionality |
| 12 | syBUS button | - | | Button for the syBUS functionality |

Tab. 2-1 Indicators and operating buttons

2.3 Connections

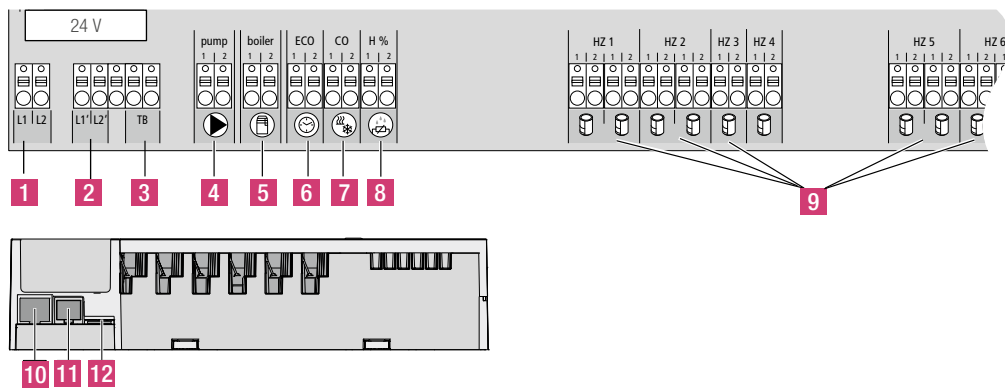

Fig. 2-3 Connections

| No. | Terminals | Function |
|-----|--------------------------|--|
| 1 | Mains transformer | Terminal for system transformer |
| 2 | Output 24 V | Output for the supply of e.g. high temperature limiter (to be provided by others) |
| 3 | High temperature limiter | Terminals for connecting high temperature limiter for protecting sensitive surfaces, to be provided by others (optional) |
| 4 | Pump | Terminal to switch pump |
| 5 | Boiler | Terminal to switch boiler or valves in case of CO mode |
| 6 | ECO | Potential-free input for external timer |
| 7 | Change over | Potential-free input (according to SELV) for external change-over signal |
| 8 | Dew point sensor | Potential-free input (according to SELV) for dew point sensor |
| 9 | Actuators | 12 connections for thermal actuators UNI 24 V |
| 10 | RJ45 connection | Ethernet interface for the integration of the base station into the home network |
| 11 | RJ12 connection | Connection for active antenna |
| 12 | microSD card slot | Used for updating firmware and individual system settings. |

Tab. 2-2 Connections

2.4 Technical data

| Base Station Nea Smart 24 V | |
|--|--|
| Ethernet | x |
| Number of heating zones | 8 |
| Number of actuators | 4x2 + 4x1 |
| Max. nominal load of all actuators | 24 W |
| Switching power per heating zone | max. 1 A |
| Pump output | 8 A ohmsch, inductive max. 200 VA |
| Operating voltage | 24 V / ±20 % |
| Mains connection | System transformer with mains plug |
| Power consumption (without pump) | 50 W (limited by the system transformer) |
| Power consumption in idle operation/with transformer | 1,1 W / 1,4 W |
| Protection class | II |
| Protection degree/overvoltage category | IP20 / III |
| Fuse | 5 x 20 mm, T2A |
| Ambient temperature | 0 °C – 60 °C |
| Storage temperature | -25 °C to +70 °C |
| Humidity | 5 to 80%, not condensing |
| Dimensions | 370 x 52 x 75 mm |
| Material | PC+ABS |
| Control accuracy of set point | ±1 K |
| Hunting | ±0,2 K |
| Max. line length | 500 m |
| rmBUS connection | polarity reversal protected |

Tab. 2-3 Technical data

3 INSTALLATION

3.1 Installation

 Electrical voltage! Danger to life!
Only carry out installation work with all power disconnected

Installation

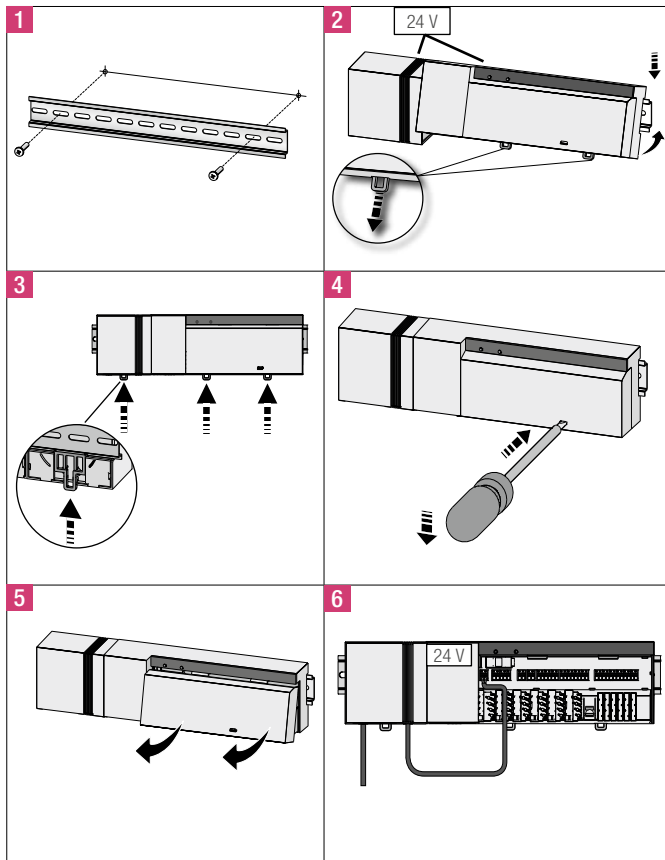



Fig. 3-1 Installation

3.2 Electrical connection

 Electrical voltage! Danger to life!
Only carry out installation work with all power disconnected

The wiring of the control system depends on many factors and must be planned and carried out carefully by the installer. The following cable sizes are compatible with the terminals:

- solid cable: 0.5 – 1.5 mm²
- multiple stranded cable: 1,0 – 1,5 mm²
- 8 - 9 mm insulation stripped off the cable
- Actuators with factory-fitted cable sleeves can be used.

 Both L1/L1' terminals share a rail and both L2/L2' terminals share a rail.

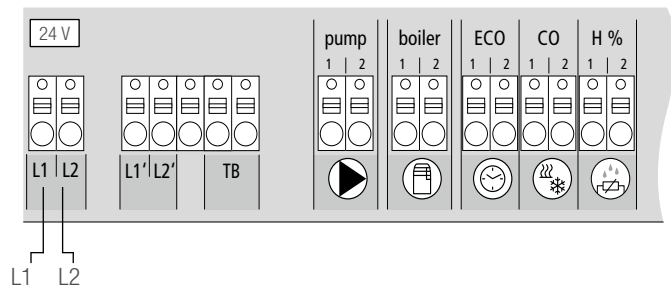

Fig. 3-2 Electrical connection

3.2.1 External change-over signal

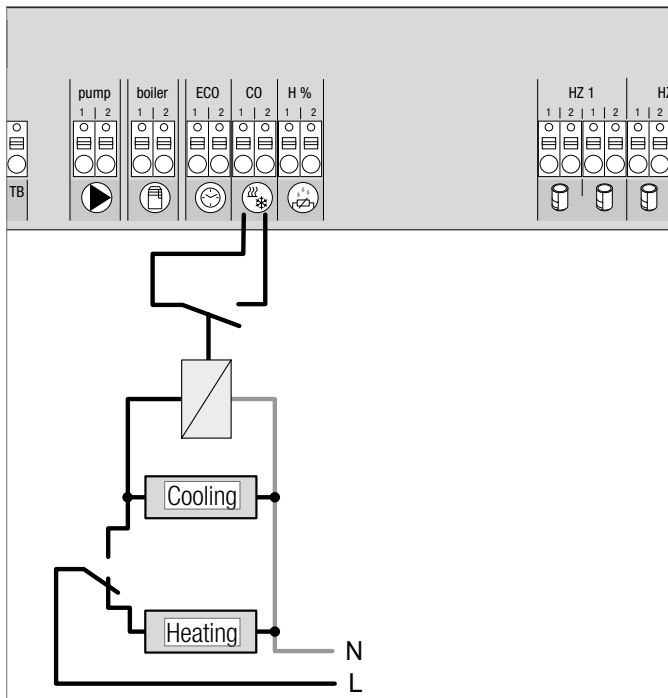

Fig. 3-3 Terminal change-over signal

If an external change-over signal is used, the overall installation switches accordingly between heating and cooling.

3.2.2 Pump/boiler/chiller

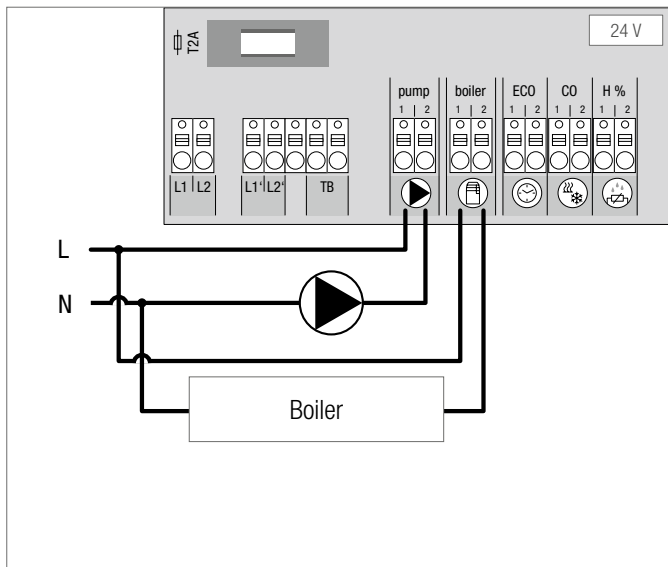

Fig. 3-4 Terminal for pump and boiler

The boiler terminal switches a boiler or chiller. Additionally, a pump can be supplied directly with power and switched. The use of a relay to switch a pump is recommended.

3.2.3 Optional dew point sensor

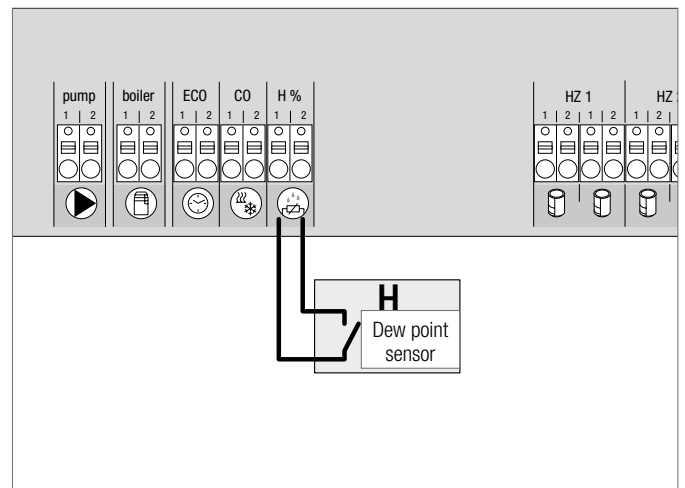

Fig. 3-5 Terminal for dew point sensor

Dew point sensors (to be provided by others) are used to prevent condensation when in cooling mode. The dew point alarm is triggered when the contact of the dew point sensor is **closed**.

3.2.4 Pilot function for change-over heating/cooling

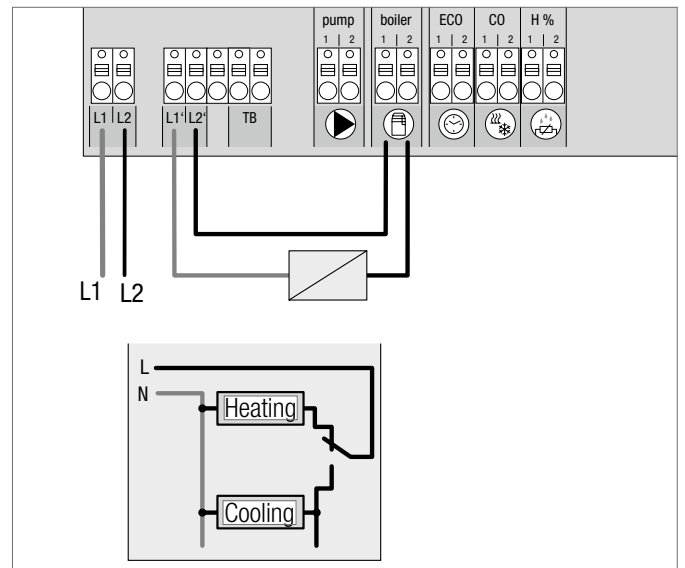

Fig. 3-6 Usage of the "Boiler" output as a pilot signal for change over

If no external change-over signal is available, the internal pilot function of the base station can be used for switching the overall installation between the operating modes Heating and Cooling. A relay used by the base station for switching over is used for this.

3.2.5 External timer

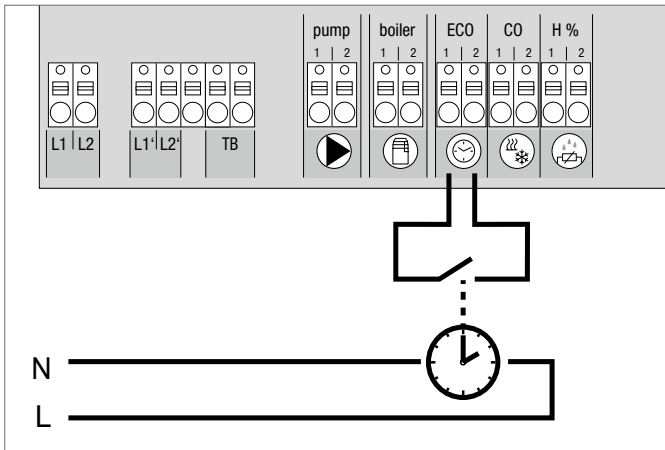

Fig. 3-7 Connection of an external timer

The base station is equipped with an ECO input for connecting an external timer in case the timers of the Nea Smart room control unit D are not be used. When the input is activated by the external timer, the heating zones are switched into set back.

3.2.6 Room BUS

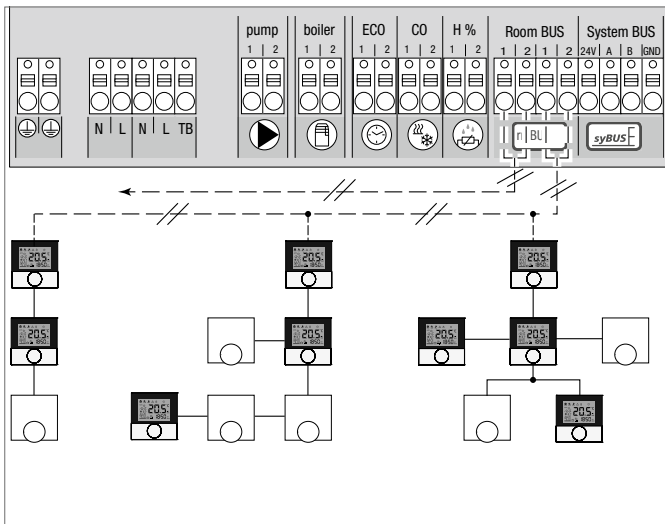

Fig. 3-8 Connection of Nea Smart room control units with base station Nea Smart

Eight room control units can be connected to the Room Bus (rmBUS). The connection of the room control units is protected against polarity reversal and can be executed in the topologies "line", "tree", or "star". An installation line I (Y) x Y 2 x 2 x 0.8 mm should ideally be used. However, it is also possible to use an existing line with at least 2 wires. The country-specific standards and regulations must always be observed, however!

3.2.7 System BUS

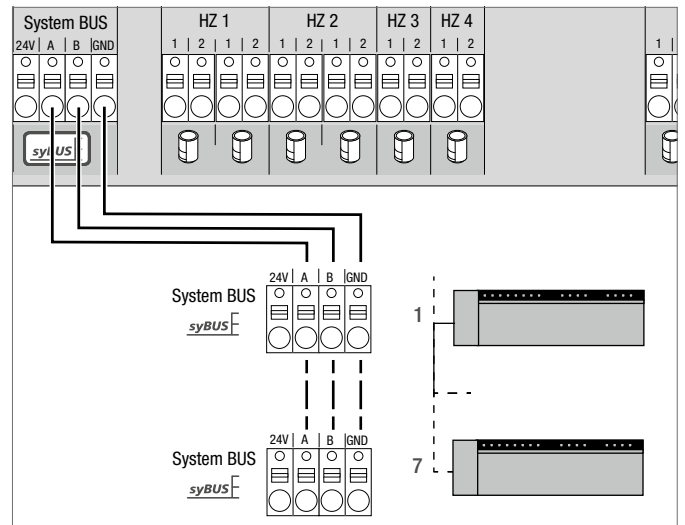

Fig. 3-9 Base station connection via system BUS

Line to be used: I (Y) St Y 2 x 2 x 0,8 mm.

Connect the shield to device earth (Gnd) on both sides!

A maximum of seven base stations can be interconnected via the system BUS (syBUS) in order to exchange global system parameters. After completing the wiring, the base stations must be paired – see section 4.2. For cable sizes <6 mm, a strain relief is necessary (to be provided by others).

3.2.8 Use of high temperature limiter

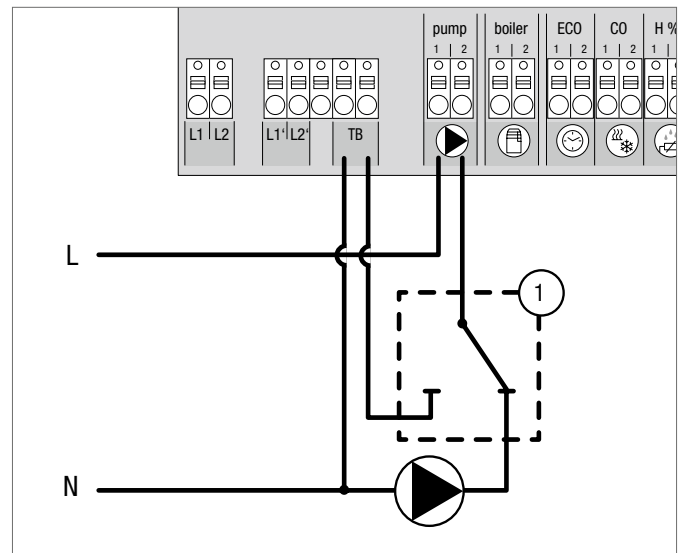

Fig. 3-10 Terminal for high temperature limiter

Connecting a high temperature limiter (1) (supplied by others). When triggered this input cuts the power to the pump and switches the input TL if any excessive flow temperatures into the floor heating are detected. If the TL input is switched, the base station automatically closes all actuators.

3.2.9 Ethernet connection

The Nea Smart base station 24 V is equipped with a RJ45 interface and an integrated web server for the control and configuration of the system via PC/laptop and over the Internet.

- Integration of the base station into the network via network cable, or direct connection to PC/laptop

Set-up in the home network:

- Open the router menu (see manual of the respective device) via the address bar in the web browser (Internet Explorer, Firefox, ...).
- Open an overview of all devices in the network.
- Compare to the MAC address (see type sign) in order to find out the IP address allocated to the base station.
- Note the IP address of the base station and enter it into the address bar of the web browser in order to open the web interface.

Direct connection to PC/laptop:

- Open the network settings in the PC/laptop and assign the IP address **192.168.100.1** as well as the subnet mask **255.255.0.0** manually to the PC.
- Access to the web interface can be gained by entering the IP address 192.168.100.100 in the address bar of your web browser.

You can find further information on the set-up as well on worldwide access via the Internet under www.rehau.com/neasmart.

4 COMMISSIONING

4.1 First commissioning

The base station is in installation mode during the first 30 minutes after switching on the mains power. The target and actual temperatures are compared in this mode, all other functions are deactivated. If the actual temperature is below the target temperature, the output allocated to the respective room control unit is activated at the base station. In this initial time all signals are activated instantly making it possible to check the correct pairing of room control units and heating zones.

- Switch on the mains power.
 - The base station is in installation mode for 30 minutes.
 - If the base station is configured for NC actuators, all heating zones are activated for 10 minutes in order to unlock the first-open function of the NC actuators.
 - The power LED (operation display) lights up permanently.

4.2 Connecting (pairing) / separating base stations

If several base stations are used in one heating system, a maximum of seven units can be connected with each other (paired) for the exchange of global system parameters via system bus (syBUS). Communication is done according to the master/slave principle. Requirements and status messages are exchanged between the units. The master unit centrally controls the directly connected functions/ components:

- CO input/output (if the pilot function is activated)
- Boiler output
- Pump output

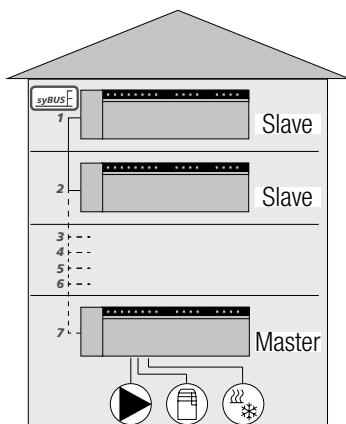

Fig. 4-1 System with multiple base units

i The base station to which the components are connected must be configured as master. Further base stations can only be paired with the master.

The pairing of base stations is done as follows:

1. Press the syBUS button of the base station to be configured as master for three seconds in order to start the pairing mode.
 - The LED "syBUS" flashes.
 - For three minutes, the pairing mode is ready to receive the pairing signal of another base station.
2. Press the syBUS button of the base station to be configured as slave two times consecutively for one second, in order pair it with the master.
 - The pairing mode ends automatically after the process has finished.
 - The LED "Master" **lights** up permanently at the master base station.
 - The LED "Master" **flashes** if the base station has been configured as slave.
3. Repeat the process for pairing another base station.

Disconnecting a base station is done as follows:

4. Press the syBUS button of the base station to be separated for three seconds in order to start the pairing mode.
 - The LED "syBUS" flashes.
5. Press the syBUS button again for approx. 10 seconds.
 - The base resets and the LED "Master" is off.

4.3 Allocation of a room control unit to a heating zone (pairing)

1. Press the rmBUS button of the base station for three seconds in order to start the pairing mode.
 - The LED "Heating zone1" flashes.
2. Select the desired heating zone by pressing again briefly.
 - For three minutes, the selected heating zone is ready to receive the pairing signal of a room control unit.
3. Activate the pairing function at the room control unit (see Room Control Unit Manual).
 - The pairing mode ends automatically after establishing a successful connection.
 - The LED of the heating zone previously selected will light up for 1 minute.
4. Repeat the process for allocating more room control units.



One Room Control Unit can be allocated to various heating zones. The allocation of several room control units to one zone is not possible.

4.4 Perform connection test

The connection test can be used to test the communication between the base station and the room control unit.

The base station must not be in pairing mode.

1. Start the connection test on the room control unit (see manual of the room control unit).
 - The heating zone allocated to the room control unit is activated for one minute and is switched off or on depending on its current operating status.
2. If there is no activation, the signal is interrupted. Check
 - whether the room control unit is paired with the base station
 - whether all connections have full contact
 - whether the communication bus wiring is not damaged.

4.5 System configuration

The base station is configured either via microSD card, the base station web interface or the service level on the Nea Smart room control unit D.

4.5.1 System configuration with microSD card

Individual settings can be made via the EZR Manager SD Card under www.ezr-home.de and transferred to the base station via the microSD card. As of software version 01.70, the base station accepts microSD cards >2 GB in the formats FAT16 or FAT32.

1. Open www.ezr-home.de via the web browser on your PC, select EZR Manager SD Card and follow the instructions online.
2. Insert the microSD card with the updated data into the base station.
 - The transfer process will start automatically and copy the updated data into the base station.
 - The LED "syBUS" flashes during the transfer process.
 - After a successful data transmission, the LED "syBUS" stops flashing.

4.5.2 Configuration with Nea Smart room control unit D

The Service level of the Nea Smart room control unit D is protected with a PIN code and may only be used by authorized specialists.



Faulty configuration leads to errors and damages the installations.

1. Press the control knob.
2. Select the menu "Service Level" and confirm by pressing.
3. Enter the 4-digit PIN (standard: 1314) by rotating and pressing.
4. Select parameters (PAr) by pressing again and enter the number code of the desired parameter (see following table).
5. Change parameters as required and confirm by pressing.

4.6 Resetting the factory settings

Attention! All user settings will be lost.

1. If present, remove the microSD Card from the base station and delete the parameter file "params_usr.bin" using a PC.
2. Press the rmBUS button on the base station for three seconds in order to start the pairing mode.
 - The LED "Heating zone1" flashes.
3. Press the rmBUS button again for 10 seconds.
 - All heating zone LEDs flash simultaneously; press the rmBUS button for another 5 seconds.
 - the LEDs light up simultaneously, and then go out.

Now the base station is reset to factory settings and behaves as it did during the first commissioning (see section 4).



Previously allocated room control units must be paired again, see section 4.3.

| No. | Parameters | Description | Default Settings | Unit |
|--|--|---|------------------|--|
| 010 | Used heating system | Adjustable per heating zone: Floor heating (FBH) standard / FBH low energy / radiator / convector passive / convector active | 1 | FBH St.=0 FBH NE=1 RAD=2 KON pas.=3 KON act.=4 |
| 020 | Deactivate heating/cooling | Deactivating the switching outputs depending on the selected operating mode (heating/cooling) | 0 | normal=0 Heating deactivated=1 Cooling deactivated=2 |
| 030 | Tamper Proof function (child safety lock) | Password required for deactivate the tamper proof function | 0 | Deactivated=0 Activated=1 |
| 031 | Password for tamper proof function | Determine PIN if parameter 30 is set to active | - | 0000..9999 |
| 040 | External sensor connected to the room control unit | Register an additional sensor for monitoring the floor temperature (FBH), the room temperature or the dew point | 2 | no sensor=0 Dew point sen.=1 Temp FBH=2 Temp room=3 |
| 050 | Backlit | Adjustable per room control unit: Duration that the display continues to be lit after operation | 15 | 0 ... 30 s default 15 s |
| 051 | Brightness | Adjustable per room control unit: adjusts the brightness of the back light of the display | 50 | 10 ... 100 % default: 50 % |
| 052 | Contrast | Adjustable per room control unit: Sets the display contrast. | 3 | 0 ... 7 default: 3 |
| 060 | Temperature calibration of actual values | A correction factor is applied to the actual temperature | 0,0 | -2.0...+2.0 K in 0.1 increments |
| 110 | Control direction switched output | Change between NC and NO actuators (only globally) | 0 | NC=0 / NO=1 |
| 115 | Use as setback input | Change-over between use of the ECO input for setback or holiday function of the room control unit. The holiday function cannot be activated any longer via the room control unit if this parameter has been set to 1. | 0 | ECO=0 Holiday=1 |
| 120 | Unit of temperature display | Toggle the display between degree Celsius and degree Fahrenheit | 0 | °C=0 °F=1 |
| Pump configuration | | | | |
| 130 | Pump output | Use the control of a local recirculation pump (in the heating circuit distributor) or a global recirculation pump (heating installation). | 0 | local=0 global=1 |
| 131 | Pump type | Selection of the used pump: Conventional Pump (KP) / High efficiency Pump (HP) | 1 | CP=0 HP=1 |
| 132 | Pump delay | Time delay between demand signal and actual activation of pump. | 4 min | [min] |
| 133 | Pump overrun | Time between closing of actuators and switching off pump. | 2 min | [min] |
| 134 | Control direction switched output | The control direction can be reversed if the pump relay is used as control output | 0 | normal=0 reversed=1 |
| 135 | Minimum running time | The minimum running time indicates how long the HP must run until it may be switched off again. | 30 min | [min] |
| 136 | Minimum standstill time | High efficiency pump: The pump may only be switched off if a minimum standstill time can be ensured. | 10 min | [min] |
| Configuration of change-over functionality / boiler relay | | | | |
| 140 | Function of relay boiler / CO output | Selection whether the switching output shall serve for controlling a pump relay, or as CO pilot | 0 | Boiler=0 CO pilot=1 |
| 141 | Boiler delay | Boiler delay for conventional pump Pump | 5 min | [min] |
| 142 | Overrun | Boiler overrun time for conventional pump Pump | 1 min | [min] |

| No. | Parameters | Description | Default Settings | Unit |
|----------------------------|--|--|------------------|------------------------------|
| 143 | Control direction switched output | If used as a control output the relay function can be reversed. | 0 | normal=0 reversed=1 |
| 160 | Frost protection | Activation of control outputs for $T_{\text{actual}} < x \text{ } ^\circ\text{C}$ | 1 | Deactivated=0 Activated=1 |
| 161 | Minimum temperature in frost protection mode | Limit room temperature at which frost protection mode is activated | 8 °C | [°C] |
| 170 | Smart Start | Adaptive self learning of the temperature behaviour of each individual heating zones | 0 | Deactivated=0 Activated=1 |
| Safe mode operation | | | | |
| 180 | Time until activated | Delay until safe mode is activated | 180 min | [min] |
| 181 | PWM cycle duration in safe mode | Duration of a PWM cycle in safe mode | 15 min | [min] |
| 182 | Cycle duration PWM heating | Control duration in heating operation | 25 % | [%] |
| 183 | Cycle duration PWM cooling | Control duration in cooling operation | 0 % | [%] |
| Valve exercise | | | | |
| 190 | Time until activated | Running time since last activation | 14 d | [d] |
| 191 | Duration of valve exercise | Duration of valve exercise (0= function deactivated) | 5 min | [min] |
| Pump exercise | | | | |
| 200 | Time until activated | Running time since last activation | 3 d | [d] |
| 201 | Time until activated | Activation duration (0 = function deactivated) | 5 min | [min] |
| 210 | First open function (FO) | Activation of all actuator outputs in installation mode | 10 min | [min] Off=0 |
| 220 | Automatic switching between summer and winter time | If activated, time switching follows automatically the CET guidelines | 1 | Deactivated=0 Activated=1 |
| 230 | Setback temperature differential | In case of activation of the setback via the external input | 2 K | [K] |

Tab. 4-1 Parameters

5 EXERCISE FUNCTIONS AND SAFE MODE

5.1 Exercise functions

The base station is equipped with many exercise functions for avoiding damage to the overall system.

5.1.1 Pump exercise

In order to avoid damage by prolonged standstill times, the pump is regularly activated in pre-set intervals. The LED "pump" lights up during these periods (see parameters 200/201).

5.1.2 Valve exercise function

During prolonged periods without valve activation (e. g. outside the heating period) all heating zones with a paired room control unit are regularly activated to prevent setting of the valves (see parameters 190/191).

5.1.3 Frost protection

Independent from the operating mode, every switched actuator output has a frost protection. When the actual room temperature falls below the preset min frost protection temperature, the corresponding actuators are opened until the min frost protection temperature is reached again in the room. The frost protection temperature can be set via the microSD card, via the software surface of the Ethernet variant or via the service level of the RBG display (parameter 161).

5.1.4 Dew point monitoring

If the installation is equipped with a dew point sensor (provided by others), the valves of all heating zones are closed if condensation is detected in order to avoid damage due to moisture. The dew point sensor input is only used during cooling operation. The alarm is triggered when the contact is **closed**.

5.1.5 High temperature limiter

If an optional high temperature limiter is used, all valves are closed when a preset temperature is exceeded in order to avoid damage to sensitive floor coverings.

5.2 Safe mode

If the base station is unable to establish a connection to a room control unit allocated to a heating zone for a preset time, the safe mode is activated automatically. In safe mode, the switched outputs at the base station are activated with a modified PWM cycle duration (parameter 181) independent from the heating system in order to avoid complete cooling of the rooms (in heating operation) or condensation (in cooling operation).

6 TROUBLESHOOTING AND CLEANING

6.1 Error messages and error handling

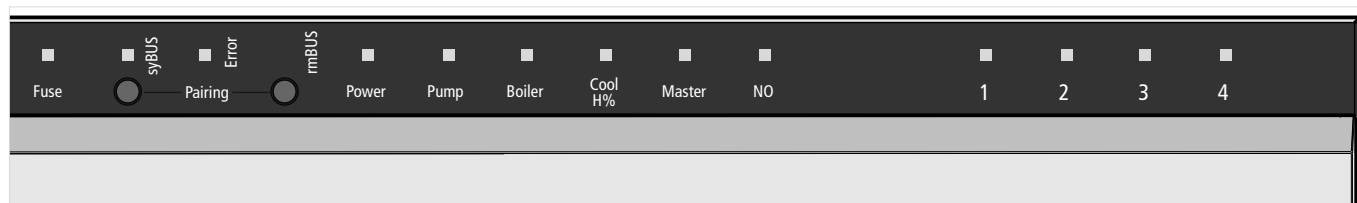

Fig. 6-1 Indicators and operating buttons

| Signal code of the LEDs | Meaning | Handling |
|--|--|---|
| <p>Fuse</p> <p>Duration in seconds</p> <p>Fuse 0 1 2 3 4</p> | Fuse defective | Change the fuse (see section 6.2) |
| <p>Error / Pump</p> <p>Duration in seconds</p> <p>Pump Error 0 1 2 3 4</p> | High temperature limiter active, valves are closed | The normal control operation is automatically resumed when the temperature drops again below the preset limit |
| <p>„Cool H%“ (only cooling operation)</p> <p>Duration in seconds</p> <p>Cool 0 1 2 3 4</p> | Condensation detected, valves are closed | The normal control operation is automatically resumed when no condensation is detected any more. |
| <p>Heating zone</p> <p>Duration in seconds</p> <p>HZ 0 1 2 3 4</p> | Safe mode active | Check bus line for interruptions. Carry out a connection test. Replace a defective room control unit. |

Tab. 6-1 Troubleshooting

LED on
 LED off

6.2 Fuse change



Electrical voltage! Danger to life!
The base station is live.

- Prior to opening always disconnect from the mains and secure in such a way that it cannot accidentally be switched on.
- Prior to replacing the fuse and connecting the power again, always check the wiring and connected components for any faults.
- Only use the specified fuse for this unit T2A, 5 x 20 mm.

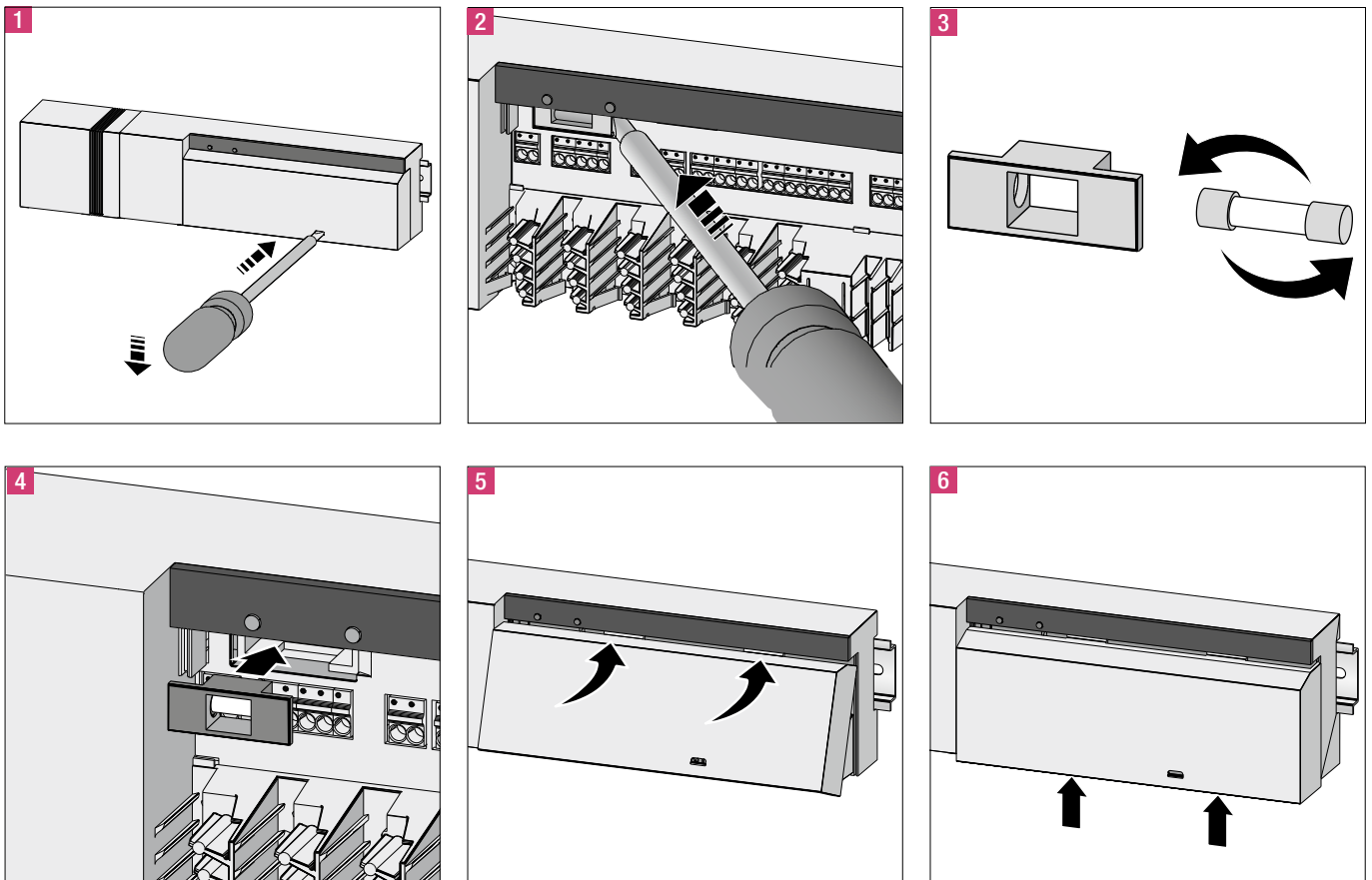

Fig. 6-2 Changing the fuse

6.3 Cleaning

Only use a dry and solvent-free, soft cloth for cleaning.

7 DECOMMISSIONING

7.1 Decommissioning



Electrical voltage! Danger to life! The base station is live.

- Prior to opening always disconnect from the mains and secure in such a way that it cannot accidentally be switched on.
- Disconnect all external voltages connected to the unit, e.g. at the pump and the boiler contacts and ensure these cannot accidentally be switched live.

7.2 Disposal



The base stations must not be disposed of with domestic waste. The operator has the duty to dispose of the units through appropriate collection points. The separate

collection and orderly disposal of all materials will help to conserve natural resources and ensure a recycling in a manner that protects human health and the environment. If you need information about collection points for your devices, please contact your local municipality or your local waste disposal services.

This document is protected by copyright. All rights based on this are reserved. No part of this publication may be translated, reproduced or transmitted in any form or by any similar means, electronic or mechanical, photocopying, recording or otherwise, or stored in a data retrieval system.

Insofar as the intended application deviates from that described in the relevant Technical Information brochure, the user must consult REHAU and must receive express written consent from REHAU before commencing this utilization. If the user fails to do so, the sole responsibility for the utilization shall lie with the individual user. In this case, the application, use and processing of products are beyond our control. Should a case of liability arise, however, this shall be limited to the value of the goods delivered by us and used by you in all cases of damage. Claims arising from granted guarantees shall become invalid in the case of intended applications that are not described in the Technical Information brochures.

REHAU SALES OFFICES

AE: Middle East, +971 4 8835677, dubai@rehaus.com **AR: Buenos Aires**, +54 11 48986000, buenosaires@rehaus.com **AT: Linz**, +43 732 3816100, linz@rehaus.com **Wien**, +43 2236 24684, wien@rehaus.com **Graz**, +43 361 403049, graz@rehaus.com **AU: Adelaide**, +61 8 82990031, adelaide@rehaus.com **Brisbane**, +61 7 55271833, brisbane@rehaus.com **Melbourne**, +61 3 95875544, melbourne@rehaus.com **Perth**, +61 8 94564311, perth@rehaus.com **Sydney**, +61 2 87414500, sydney@rehaus.com **AZ: Baku**, +99 412 5110792, baku@rehaus.com **BA: Sarajevo**, +387 33 475500, sarajevo@rehaus.com **BE: Bruxelles**, +32 16 399911, bruxelles@rehaus.com **BG: Sofia**, +359 2 8920471, sofia@rehaus.com **BR: Arapongas**, +55 43 31522004, arapongas@rehaus.com **Belo Horizonte**, +55 31 33097737, belo Horizonte@rehaus.com **Caxias do Sul**, +55 54 32146606, caxias@rehaus.com **Mirassol**, +55 17 32535190, mirassol@rehaus.com **Recife**, +55 81 32028100, recife@rehaus.com **BY: Minsk**, +375 17 2450209, minsk@rehaus.com **CA: Moncton**, +1 506 5382346, moncton@rehaus.com **Montreal**, +1 514 9050345, montreal@rehaus.com **St. John's**, +1 709 7473909, stjohns@rehaus.com **Toronto**, +1 905 3353284, toronto@rehaus.com **Vancouver**, +1 604 6264666, vancouver@rehaus.com **CH: Bern**, +41 31 720120, bern@rehaus.com **Vevey**, +41 21 9482636, vevey@rehaus.com **Zuerich**, +41 44 8397979, zuerich@rehaus.com **CN: Guangzhou**, +86 20 87760343, guangzhou@rehaus.com **Beijing**, +86 10 64282956, beijing@rehaus.com **Shanghai**, +86 21 63551155, shanghai@rehaus.com **Chengdu**, +86 28 86283218, chengdu@rehaus.com **Xian**, +86 29 68597000, xian@rehaus.com **Shenyang**, +86 24 22876807, shenyang@rehaus.com **Qingdao**, +86 32 86678190, qingdao@rehaus.com **CO: Bogota**, +57 1 898 528687, bogota@rehaus.com **CZ: Praha**, +420 272 190111, praha@rehaus.com **DE: Berlin**, +49 30 667660, berlin@rehaus.com **Bielefeld**, +49 521 208400, bielefeld@rehaus.com **Bochum**, +49 234 689030, bochum@rehaus.com **Frankfurt**, +49 6074 40900, frankfurt@rehaus.com **Hamburg**, +49 40 733402100, hamburg@rehaus.com **Hannover**, +49 5136 891181, hannover@rehaus.com **Leipzig**, +49 34292 820, leipzig@rehaus.com **München**, +49 8102 860, muenchen@rehaus.com **Nürnberg**, +49 9131 934080, nuernberg@rehaus.com **Stuttgart**, +49 7159 16010, stuttgart@rehaus.com **Ingolstadt**, +49 841 142626200, ingolstadt@rehaus.com **DK: København**, +45 46 773700, københavn@rehaus.com **EE: Tallinn**, +372 6025850, tallinn@rehaus.com **ES: Barcelona**, +34 93 6353500, barcelona@rehaus.com **Bilbao**, +34 94 4538636, bilbao@rehaus.com **Madrid**, +34 91 6839425, madrid@rehaus.com **Fi: Helsinki**, +358 9 87709900, helsinki@rehaus.com **FR: Lyon**, +33 4 72026300, lyon@rehaus.com **Metz**, +33 6 8500, metz@rehaus.com **Paris**, +33 1 34836450, paris@rehaus.com **GB: Glasgow**, +44 1698 503700, glasgow@rehaus.com **Manchester**, +44 161 7777400, manchester@rehaus.com **Slough**, +44 1753 588500, slough@rehaus.com **Ross on Wye**, +44 1989 762643, rowy@rehaus.com **London**, +44 207 3078590, london@rehaus.com **GE: Tbilisi**, +995 32 559909, tbilisi@rehaus.com **GR: Athens**, +30 21 06682500, athens@rehaus.com **Thessaloniki**, +30 2310 633301, thessaloniki@rehaus.com **HK: Hongkong**, +8 52 28987080, hongkong@rehaus.com **HR: Zagreb**, +385 1 3444711, zagreb@rehaus.com **HU: Budapest**, +36 23 530700, budapest@rehaus.com **ID: Jakarta**, +62 21 45871030, jakarta@rehaus.com **IE: Dublin**, +353 1 8165020, dublin@rehaus.com **IN: Mumbai**, +91 22 61485858, mumbai@rehaus.com **New Delhi**, +91 11 45044700, newdelhi@rehaus.com **Bangalore**, +91 80 2222001314, bangalore@rehaus.com **IT: Pesaro**, +39 0721 200611, pesaro@rehaus.com **Roma**, +39 06 90061311, roma@rehaus.com **Treviso**, +39 0422 726511, treviso@rehaus.com **JP: Tokyo**, +81 3 57962102, tokyo@rehaus.com **KR: Seoul**, +82 2 50111656, seoul@rehaus.com **KZ: Almaty**, +7 727 3941301, almaty@rehaus.com **LT: Vilnius**, +370 5 2461400, vilnius@rehaus.com **LV: Riga**, +371 6 7609080, riga@rehaus.com **MA: Casablanca**, +212 522250593, casablanca@rehaus.com **MK: Skopje**, +389 2 2402, skopje@rehaus.com **MX: Celaya**, +52 461 6188000, celaya@rehaus.com **Monterrey**, +52 81 81210130, monterrey@rehaus.com **NL: Nijkerk**, +31 33 2479911, nijkerk@rehaus.com **NO: Oslo**, +47 2 2514150, oslo@rehaus.com **NZ: Auckland**, +64 9 2722264, auckland@rehaus.com **PE: Lima**, +51 1 2261713, lima@rehaus.com **PL: Katowice**, +48 32 7755100, katowice@rehaus.com **Warszawa**, +48 22 2056300, warszawa@rehaus.com **PT: Lisboa**, +351 21 8987050, lisboa@rehaus.com **Oporto**, +351 22 94464, oporto@rehaus.com **QA: Qatar**, +974 44101608, qatar@rehaus.com **RO: Bacau**, +40 234 512066, bacau@rehaus.com **Bucuresti**, +40 21 2665180, bucaresti@rehaus.com **Cluj Napoca**, +40 264 415211, clujnapoca@rehaus.com **RS: Beograd**, +381 11 3770301, beograd@rehaus.com **RU: Chabarowsk**, +7 4212 411218, chabarowsk@rehaus.com **Jekaterinburg**, +7 343 2535305, jekatarinburg@rehaus.com **Krasnodar**, +7 861 2103636, krasnodar@rehaus.com **Nishnij Nowgorod**, +7 831 4678078, nishnijnowgorod@rehaus.com **Novosibirsk**, +7 3832 000353, novosibirsk@rehaus.com **Rostow am Don**, +7 8632 978444, rostow@rehaus.com **Samara**, +7 8462 698058, samara@rehaus.com **St. Petersburg**, +7 812 3266207, stpetersburg@rehaus.com **Woronesch**, +7 4732 611858, woronesch@rehaus.com **SE: Orebro**, +46 19 206400, orebro@rehaus.com **SG: Singapore**, +65 63926006, singapore@rehaus.com **SK: Bratislava**, +421 2 68209110, bratislava@rehaus.com **TH: Bangkok**, +66 27635100, bangkok@rehaus.com **TW: Taipei**, +886 2 87803899, taipei@rehaus.com **UA: Dnepropetrowsk**, +380 56 3705028, dnepropetrowsk@rehaus.com **Kiev**, +380 44 4677710, kiev@rehaus.com **Odesa**, +380 48 7800708, odesa@rehaus.com **Lviv**, +380 32 2244810, livv@rehaus.com **US: Detroit**, +1 248 8489100, detroit@rehaus.com **Grand Rapids**, +1 616 2856867, grandrapids@rehaus.com **Los Angeles**, +1 951 5499017, losangeles@rehaus.com **Minneapolis**, +1 612 2530576, minneapolis@rehaus.com **VN: Ho Chi Minh City**, +84 8 38233030, sales.vietnam@rehaus.com **ZA: Durban**, +27 31 7657447, durban@rehaus.com **Johannesburg**, +27 11 2011300, johannesburg@rehaus.com **Cape Town**, +27 21 9821254, capetown@rehaus.com **East London**, +27 43 7095400, eastlondon@rehaus.com **If there is no sales office in your country**, +49 9131 925888, salesoffice.ibd@rehaus.com

© REHAU AG + Co
Rheniumhaus
95111 Rehaus
Subject to technical changes.

954621 EN 05.2017